

DESPIECE DE LA HERRAMIENTA

Usted encontrará con un círculo las piezas de desgaste recomendadas para mantener en stock.

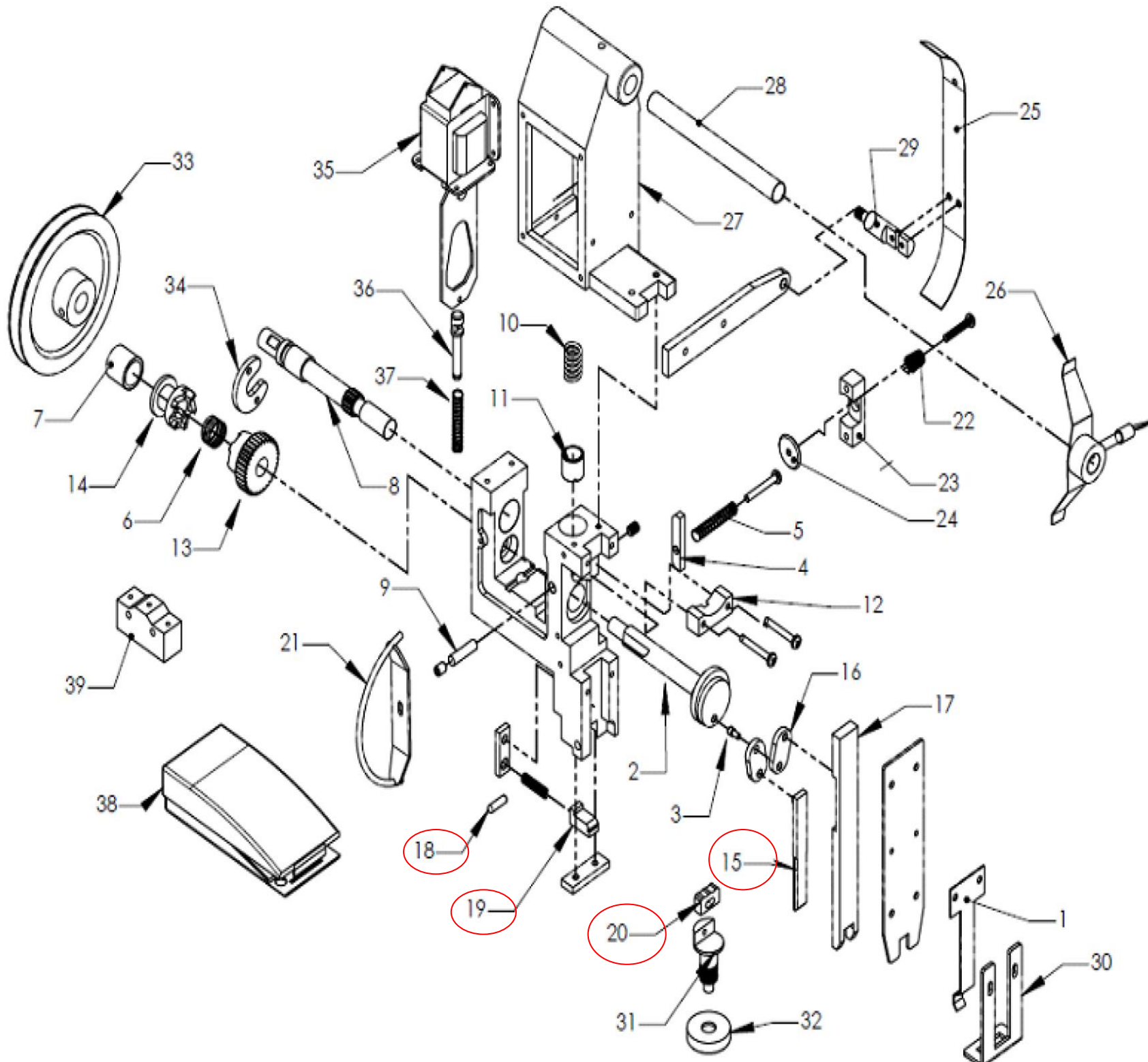

015: Lanceta 018: Round die 019: Formador 020: Cuchilla

KIT: una lanceta, un round die, un formador y una cuchilla

*Partes de desgaste común para servicio preventivo (por cada 12 meses de uso)

003: Crank Pin 015: Lanceta 017: Bender 020: Cuchilla 035: Solenoid 039 : Micro Switch

LISTA DE PARTES
MODELO: BSC10-110

Item	Part No.	Description	Q'ty	Specification	P. Lista
001	1	SPRING PLATE	1		416.57
002	2	WIRE FEEDING SHAFT	1		4,165.71
003	3	CRANK PIN	1		277.71
004	4	POSITION BRAKER	1		416.57
005	5	SPRING OF 3-4	1		83.31
006	6	CLUTCH SPRING	1		111.09
007	7	CLUTCH POSITION RING	1		277.71
008	8	DRVIER SHAFT	1		2,221.71
009	9	SHAFT HEIGHT ADJ	1		277.71
010	10	SPRING	1		138.86
011	11	SPRING HOUSING	1		555.43
012	12	WIRE GUIDE BLOCK	1		1,110.86
013	13	GEAR	1		1,666.29
014	14	CLUTCH	1		1,110.86
015	15	DRIVER	1		972.00
016	16	CRANK ROD	2		416.57
017	17	BENDER	1		4,721.14
018	18	ROUND DIE	1		555.43
019	19	FORMER	1		1,110.86
020	20	CLINCHER	1		833.14
021	21	WIRE FUBE	1		1,388.57
022	22	SPRING	1		138.86
023	23	ONE WAY BLOCK	1		1,110.86
024	24	STOPPER	1		555.43
025	25	WIRE GUIDE	1		833.14
026	26	SPOOL BRAKER	1		694.29
027	27	SOLENOID HOUSING	1		2,777.14
028	28	SPOOL HOLDER	1		277.71
029	29	WIRE GUIDE HOLDER	1		-
030	30	FINGER GUARD	1		694.29
031	31	CLINCHER HOLDER	1		-
032	32	NUT	1		-
033	33	MOTOR PULLY	1		1,110.86
034	34	SHAFT FIXER	1		833.14
035	35	SOLENOID	1		2,082.86
036	36	CLUTCH CONTROLER	1		1,110.86
037	37	SPRING	2		83.31
038	38	CONTROL PEDAL	1		1,666.29
039	39	MICRO SWITCH	1		555.43
091	91	PLACA	1		1,091.21

*Precios en moneda nacional